



2023

Form A

Pilot ID

Flight #

CIVA Intermediate Free Known

No	Symbol	Cat. No.	K	Total K	Grade	Pos	Remarks	Item	K	Grade
1		8.5.7.3 9.1.3.3 9.1.3.1 9.1.2.4	10 6 2 10	Fig D 28	.			Pos.	30	
								Harm.	0	
2		1.2.8.3 9.11.1.6 9.4.2.2	15 3 7	Fig A 25	.			Fig K	Total K	
								200	230	
3		7.2.1.4 9.2.3.4	6 9	15	.			<b>Penalties</b>		
								Too Low		
4		7.4.1.1 9.9.3.4	10 11	21	.			Too High		
								Interruptions		
5		5.3.1.1 9.8.5.1	18 3	Fig B 21	.			Insertions		
								Trg Violation		
6		8.4.3.1 9.1.1.1	15 6	Fig C 21	.			Wing Rocks		
								Disqual Fig		
7		8.5.6.1 9.1.3.4 9.4.4.2	10 8 5	23	.			Other(note...)		
								<b>Final Freestyle</b>		
8		7.4.3.1	14	Fig E 14	.			Duration	Min	Sec
9		7.2.2.1 9.2.3.6	6 12	18	.			<b>Judges Details</b>		
								Signature		
10		2.1.3.1	14	14	.			Name		
								Number		

\_\_\_\_\_  
Pilot

\_\_\_\_\_  
A/C



2023		Form B
Pilot ID	CIVA Intermediate Free Known	Flight #

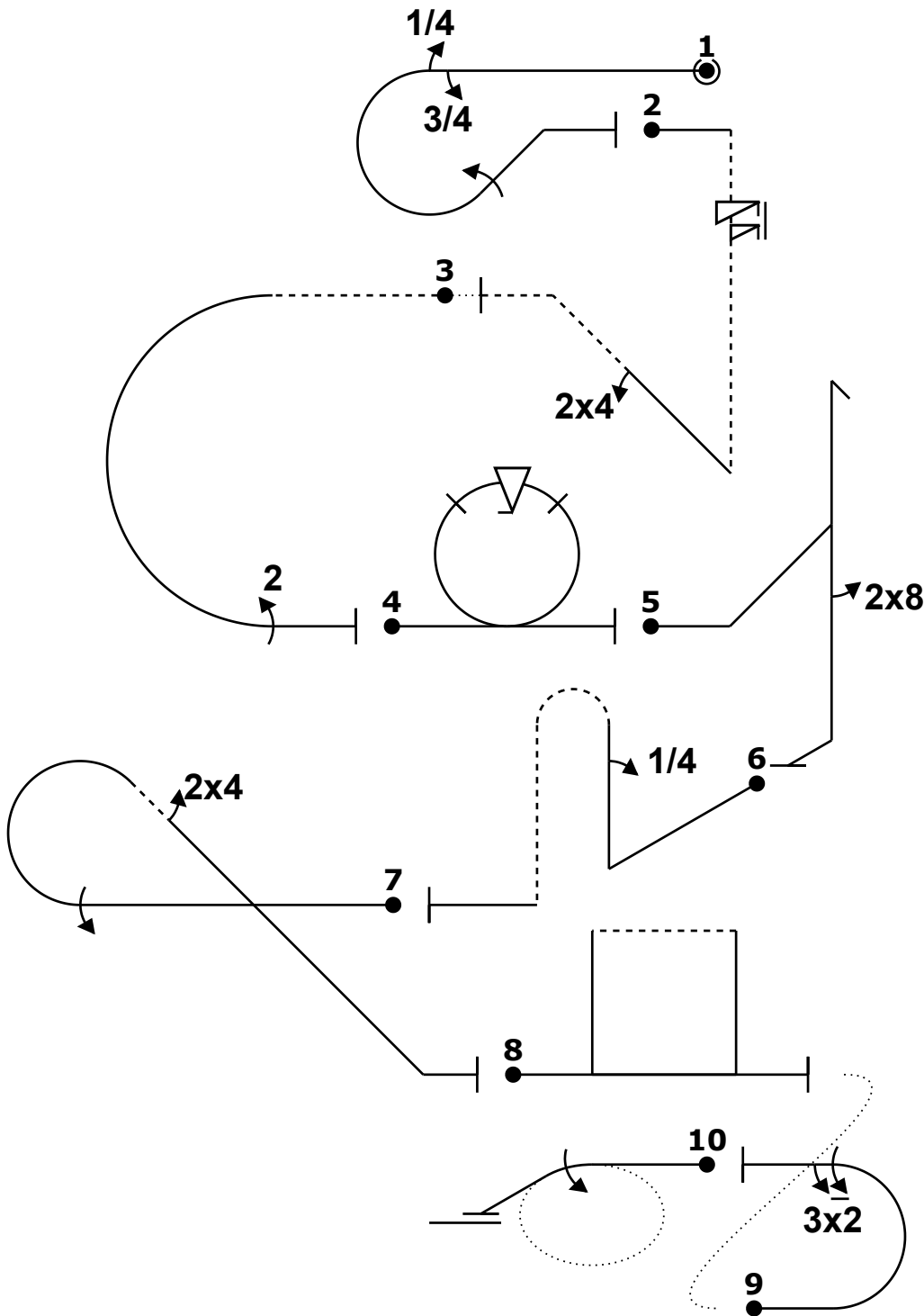
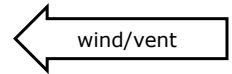

Power			
Fig	Aresti	K	
1 D	8.5.7.3	10	28
	9.1.3.3	6	
	9.1.3.1	2	
	9.1.2.4	10	
2 A	1.2.8.3	15	25
	9.11.1.6	3	
	9.4.2.2	7	
3	7.2.1.4	6	15
	9.2.3.4	9	
4	7.4.1.1	10	21
	9.9.3.4	11	
5 B	5.3.1.1	18	21
	9.8.5.1	3	
6 C	8.4.3.1	15	21
	9.1.1.1	6	
7	8.5.6.1	10	23
	9.1.3.4	8	
	9.4.4.2	5	
8 E	7.4.3.1	14	14
9	7.2.2.1	6	18
	9.2.3.6	12	
10	2.1.3.1	14	14
<b>Total K = 200</b> (max K = 200)			

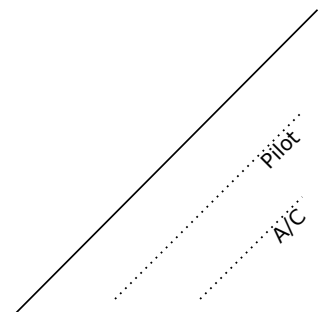



2023		Form C
Pilot ID	CIVA Intermediate Free Known	Flight #

